

# Eðlisfræði II V

**Lokapróf**

**6. júní 2016 kl. 9:00 - 12:00**

Leyfileg hjálpargögn eru skriffæri og vasareiknir

### 1. Spennudeiling – Voltage division (7)

Ef gefið er að viðnámið  $R_1 = 5 \text{ k}\Omega$  og viðnámið  $R_2 = 15 \text{ k}\Omega$  og að  $V_1 = 10 \text{ V}$  hvað er þá  $V_2$  ?

Given is that the resistor  $R_1 = 5 \text{ k}\Omega$  and the resistor  $R_2 = 15 \text{ k}\Omega$  and  $V_1 = 10 \text{ V}$  what is the value of  $V_2$  ?

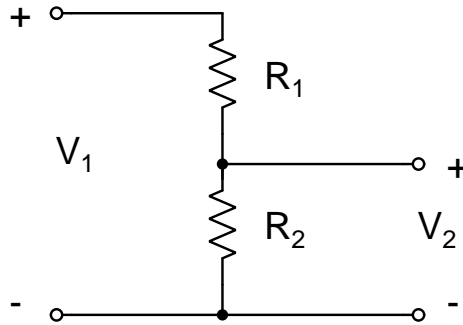

### 2. Spennir – Transformer (7)

Gerum ráð fyrir forvafi spennis sem ber ac strauminn  $i_1$  og spennan er  $v_1$ . Þessu er umbreytt um forvafsspólu með 100 vafninga og bakvafsspólu með 5 vafninga. Hver er straumurinn  $i_2$  og spennan  $v_2$  í bakvafinu ?

Suppose a primary circuit carries an ac current  $i_1$  and voltage  $v_1$ . We transform this through a primary coil of 100 turns to a secondary coil of 5 turns. What are the current  $i_2$  and voltage  $v_2$  in the secondary circuit ?

### 3. Gauss flötur – Gaussian surface (7)

Ákvarðið rafflæðið fyrir Gauss flöt sem umlykur 100 milljón rafeindir.

Determine the electric flux for a gaussian surface that encloses 100 million electrons.

#### 4. Línuhleðsla og rafsvið – Line charge and electric field (16)

Hleðslan  $-3q$  er jafndreifð eftir línu frá

$$(x, y) = \left(-L, -\frac{L}{2}\right) \quad \text{til} \quad (x, y) = \left(-L, \frac{L}{2}\right)$$

(a) Hvert er framlag  $dE_x$  og  $dE_y$ , til  $x$  og  $y$  þáttar rafsviðsins í upphafspunkti vegna örsmæðarhleðslu af lengd  $dy$  sem staðsett er á línunni í fjarlægðinni  $y$  yfir  $x$ -ásnum ?

(b) Hver er jafnan sem lýsir heildar rafsviðinu í upphafspunkti vegna þessarar línuhleðslu ?

A charge of  $-3q$  is uniformly distributed along a line from

$$(x, y) = \left(-L, -\frac{L}{2}\right) \quad \text{to} \quad (x, y) = \left(-L, \frac{L}{2}\right)$$

(a) What are the contributions,  $dE_x$  and  $dE_y$ , to the  $x$  and  $y$  components of the electric field at the origin due to a small element of charge of length  $dy$  located along the line a distance  $y$  above the  $x$  axis ?

(b) What is the expression for the total electric field at the origin due to this line of charge ?

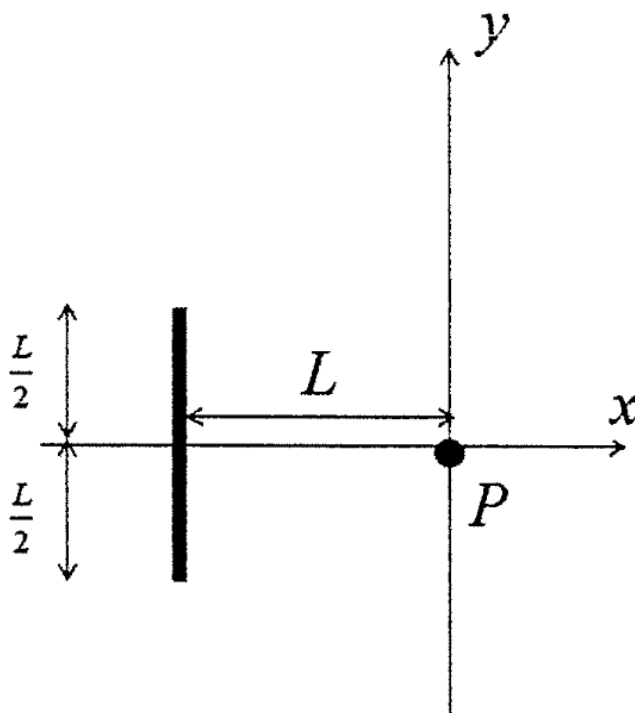

### 5. Segulkraftur og vægi – Magnetic force and torque (18)

Þríhyrnings vírlykkja er staðsett í einsleitum segulsviði. Sú hlið lykkjunnar sem er merkt ca er samsíða segulsviðslínunum og styrkur segulsviðsins er 0.6 T. Straumur sem er 1.7 A rennur um lykkjuna rangsælis. Hliðar lykkjunnar bc og ca eru 2.0 m langar.

- (a) Hver er segulkrafturinn (gefa bæði styrk og stefnu) á sérhverja hliðanna ab, bc og ca ?
- (b) Hvert er segulvægi lykkjunnar,  $\mu$ , (gefa bæði styrk og stefnu) ?
- (c) Hvert er vægi lykkjunnar,  $\tau$ , (gefa bæði styrk og stefnu) ?

A right-triangular loop of wire is situated in a region of uniform magnetic field. The side of the loop labeled ca is parallel to the field lines and the magnitude of the field is 0.6 T. A current of 1.7 A circulates counterclockwise around the loop. Sides bc and ca of the loop are 2.0 m long.

- (a) What is the magnetic force (give magnitude and direction) on each of the sides ab, bc and ca ?
- (b) What is the magnetic moment,  $\mu$ , of the loop (give magnitude and direction) ?
- (c) What is the torque,  $\tau$ , on the loop (give magnitude and direction) ?

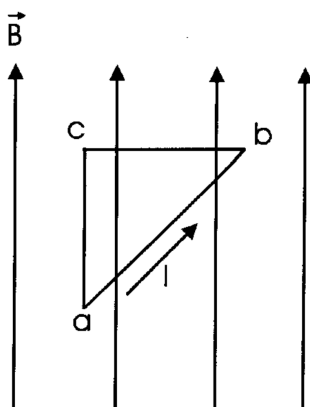

6. Plötupéttir og færslustraumur – Parallel plate capacitor and displacement current (18)

Á myndinni hér að neðan er plötupéttir sem hefur ferningslaga plötur af hliðarlengd  $L = 1.0$  m.  $2.0$  A straumur hleður upp þéttinn, og veldur einsleitu rafsviði  $\mathbf{E}$  milli platnanna, þar sem  $\mathbf{E}$  er hornrétt á plöturnar.

- (a) Hver er færslustraumurinn  $i_d$  um svæðið á milli platnanna ?
- (b) Hvað er  $dE/dt$  á þessu svæði ?
- (c) Hver er færslustraumurinn sem er innan fernings sem táknaður er með brotalínu af hliðarlengd  $d = 0.5$  m ?
- (d) Hvað er  $\oint \mathbf{B} \cdot d\ell$  um þessa fernings brotalínu ?

In the figure below, a parallel plate capacitor has square plates of edge length  $L = 1.0$  m. A current of  $2.0$  A charges the capacitor, producing a uniform electric field  $\mathbf{E}$  between the plates, with  $\mathbf{E}$  perpendicular to the plates.

- (a) What is the displacement current  $i_d$  through the region between the plates ?
- (b) What is  $dE/dt$  in this region ?
- (c) What is the displacement current encircled by the square dashed path of edge  $d = 0.5$  m ?
- (d) What is  $\oint \mathbf{B} \cdot d\ell$  around this square dashed path ?

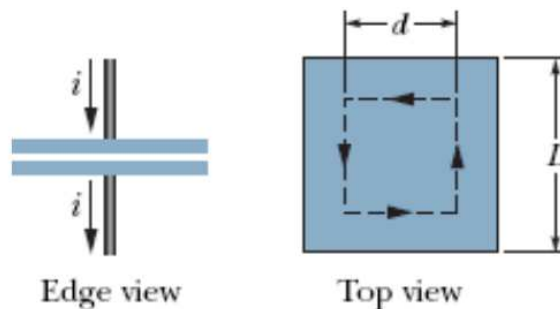

## 7. Langspóla – Solenoid (9)

Langspóla af lengd 18 cm samanstendur af vafningum sem eru þétt vafðir um trékjarna. Segulsviðsstyrkurinn innan langspólunnar nærri miðju hennar er 2.0 mT þegar tiltekinn straumur fer um spóluna. Ef að vafningunum er nú ýtt aðeins í sundur þannig að lengd langspólunnar verði 21 cm, án þess að breyta stærð vafninganna, hver verður þá segulsviðsstyrkurinn nærri miðju langspólunnar ef sami straumur fer um hana og áður ?

A solenoid of length 18 cm consists of closely spaced coils of wire wrapped tightly around a wooden core. The magnetic field strength is 2.0 mT inside the solenoid near its center when a certain current flows through the coils. If the coils of the solenoid are now pulled apart slightly, stretching it to 21 cm without appreciably changing the size of the coils, what does the magnetic field become near the center of the solenoid when the same current flows through the coils ?

## 8. Jafngildisrýmd – Equivalent capacitance (7)

Finna skal einn þétti sem er jafngildur þéttunum eins og þeir eru tengdir í rásinni hér að neðan.

Find a single capacitor that is equivalent to the capacitors connected as in the figure below.

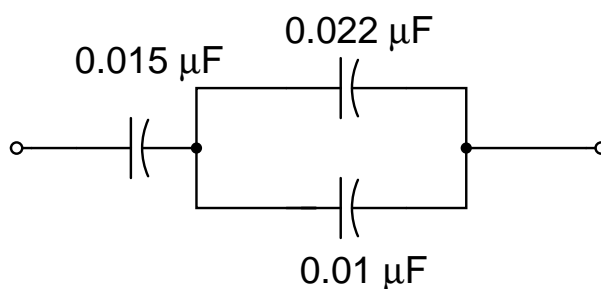

### 9. Langir samsíða vírar – Long parallel wires (3)

Tveir mjög langir samsíða vírar sem eru í fjarlægðinni  $d$  hvor frá öðrum bera jafnstóra strauma í andstæðar stefnur. Staðsetningin þar sem heildar segulsviðið er núll er

- (A) miðja vegu milli víranna.
- (B) í fjarlægðinni  $d/2$  vinstra megin við vinstri vörinn og í fjarlægðinni  $d/2$  hægra megin við hægri vörinn.
- (C) í fjarlægðinni  $d$  vinstra megin við vinstri vörinn og í fjarlægðinni  $d$  hægra megin við hægri vörinn.
- (D) í fjarlægðinni  $d/\sqrt{2}$  vinstra megin við vinstri vörinn og í fjarlægðinni  $d/\sqrt{2}$  hægra megin við hægri vörinn.
- (E) Heildar sviðið er hvergi núll.

Two very long parallel wires are a distance  $d$  apart and carry equal currents in opposite directions. The locations where the net magnetic field due to these currents is equal to zero are

- (A) midway between the wires.
- (B) a distance  $d/2$  to the left of the left wire and also a distance  $d/2$  to the right of the right wire.
- (C) a distance  $d$  to the left of the left wire and also a distance  $d$  to the right of the right wire.
- (D) a distance  $d/\sqrt{2}$  to the left of the left wire and also a distance  $d/\sqrt{2}$  to the right of the right wire.
- (E) The net field is not zero anywhere.

10. Lykkja í einsleitu ytra segulsviði – Loop in a uniform external magnetic field (8)

Hringlaga lykkja af radía 0.10 m snýst í einsleitu ytra segulsviði sem er 0.20 T. Finna skal segulflæðið um lykkjuna vegna ytra sviðsins þegar plan lykkjunnar og segulsviðsvigurinn eru

- (a) samsíða.
- (b) hornrétt.
- (c) undir  $30^\circ$  horni við hvort annað.

A circular loop of radius 0.10 m is rotating in a uniform external magnetic field of 0.20 T. Find the magnetic flux through the loop due to the external field when the plane of the loop and the magnetic field vector are

- (a) parallel.
- (b) perpendicular.
- (c) at an angle of  $30^\circ$  with each other.



## FASTAR

$$m_e = 9.1095 \times 10^{31} \text{ kg}$$

$$e = 1.6022 \times 10^{-19} \text{ C}$$

$$\epsilon_0 = 8.8542 \times 10^{-12} \text{ F/m}$$

$$\mu_0 = 4\pi \times 10^{-7} \text{ H/m}$$

$$h = 6.6262 \times 10^{-34} \text{ Js}$$

$$\hbar = 1.0546 \times 10^{-34} \text{ Js}$$

$$c = 2.9979 \times 10^8 \text{ m/s}$$

## J Ö F N U R

### RAFSTÖÐUFRÆÐI

$$k = 1/(4\pi\epsilon_0)$$

$$\text{Coulomb } \mathbf{F} = \frac{kqQ}{r^2} \hat{\mathbf{r}}$$

Rafsvið

$$\mathbf{E} = \frac{kQ}{r^2} \hat{\mathbf{r}} \quad \mathbf{E} = k \int \frac{dq}{r^2} \hat{\mathbf{r}}$$

$$\text{Umhverfis langan vír } E = 2k\lambda/R$$

$$\text{Við þynnu } E = \sigma/2\epsilon_0$$

$$\text{Milli þynna, þéttir } E = \sigma/\epsilon_0$$

$$\text{Tvískautsvægi } \mathbf{p} = q \mathbf{d}$$

$$\mathbf{E} = k(-\mathbf{p}/r^3 + 3(\mathbf{p} \cdot \mathbf{r})\mathbf{r}/r^5)$$

$$\boldsymbol{\tau} = \mathbf{p} \times \mathbf{E}$$

$$U = -\mathbf{p} \cdot \mathbf{E}$$

$$\mathbf{F} = \nabla(\mathbf{p} \cdot \mathbf{E})$$

$$\text{Rafflæði } \Phi_E = \oint \mathbf{E} \cdot d\mathbf{A}$$

$$\text{Lögmál Gauss } \oint \mathbf{E} \cdot d\mathbf{A} = \frac{Q}{\epsilon_0}$$

Rafmætti

$$V_B - V_A = - \int_A^B \mathbf{E} \cdot d\mathbf{s}$$

$$\text{í einsleitu sviði } \Delta V = \pm E d$$

$$\text{fyrir punkthleðslu } V = \frac{kQ}{r}$$

$$\text{dreifð hleðsla } V = \int \frac{k dq}{r}$$

$$\text{Mættisorka } U = qV$$

$$\mathbf{E} = -\nabla V$$

$$\text{Rýmd } C = Q/V$$

$$\text{Plötubéttir } C = \epsilon_0 A/d$$

$$\text{Hliðt. } C_{eq} = C_1 + C_2 + \dots + C_N$$

$$\text{Raðt. } 1/C_{eq} = 1/C_1 + 1/C_2 + \dots + 1/C_N$$

$$U_E = Q^2/2C = QV/2 = CV^2/2$$

$$\text{Orkuþéttleiki } u_E = \frac{1}{2} \epsilon_0 E^2$$

$$\text{Rafsvari } C = \kappa C_0 \quad E_D = E_0/\kappa$$

### RAFSEGULFRÆÐI

$$\text{Straumur } I = dQ/dt \quad J = I/A$$

$$\mathbf{J} = nq \mathbf{v}_d \quad \mathbf{J} = (1/\rho)\mathbf{E} = \sigma \mathbf{E}$$

$$R = V/I \quad R = \rho l/A \quad V = IR$$

$$P = IV = I^2 R = V^2/R$$

$$\rho = \rho_0(1 + \alpha(T - T_0))$$

$$\text{Kirchhoff: } \Sigma I = 0 \quad \Sigma V = 0$$

Viðnám

$$\text{raðt. } R_{eq} = R_1 + R_2 + \dots + R_N$$

$$\text{hliðt. } 1/R_{eq} = 1/R_1 + 1/R_2 + \dots + 1/R_N$$

Afhleðsla og hleðsla þéttis

$$Q = Q_0 e^{-t/\tau}; \quad I = I_0 e^{-t/\tau}$$

$$\tau = RC$$

$$Q = Q_0(1 - e^{-t/\tau}); \quad I = I_0 e^{-t/\tau}$$

$$\begin{aligned}\mathbf{F} &= q \mathbf{v} \times \mathbf{B} & \mathbf{F} &= I \ell \times \mathbf{B} \\ d\mathbf{F} &= I d\ell \times \mathbf{B} & \boldsymbol{\mu} &= NIA \hat{\mathbf{n}} \\ \boldsymbol{\tau} &= \boldsymbol{\mu} \times \mathbf{B} & U &= -\boldsymbol{\mu} \cdot \mathbf{B}\end{aligned}$$

Rafeind á braut  $evB = mv^2/r$

$$\boldsymbol{\mu} = -(e/2m)\mathbf{L} \quad L = mvr$$

Lorentz  $\mathbf{F} = q(\mathbf{E} + \mathbf{v} \times \mathbf{B})$

Hall  $nq = \frac{-J_x B_y}{E_z}$

Langur vír  $B = \mu_0 I / 2\pi R$

Tveir vírar  $F/\ell = \frac{\mu_0 I_1 I_2}{2\pi d}$

Biot-Savart

$$d\mathbf{B} = \frac{\mu_0}{4\pi} \frac{Id\ell \times \hat{\mathbf{r}}}{r^2}$$

Spóla  $B = \frac{1}{2}\mu_0 nI(\sin\theta_2 - \sin\theta_1)$

Ampere  $\oint \mathbf{B} \cdot d\ell = \mu_0 I$

Segulflæði  $\Phi_B = \mathbf{B} \cdot \mathbf{A}$

$$\Phi_B = \int \mathbf{B} \cdot d\mathbf{A}$$

Faraday  $\mathcal{E} = -\frac{d\Phi_B}{dt}$

Sjálfspan, víxlspan

$$\mathcal{E}_{11} = -L_1 \frac{dI_1}{dt} \quad N_1 \Phi_{11} = L_1 I_1$$

$$\mathcal{E}_{12} = -M \frac{dI_2}{dt} \quad N_1 \Phi_{12} = M I_2$$

Spóla  $L = \mu_0 n^2 A \ell$

LR-rás

$$I = I_0(1 - e^{-t/\tau})$$

$$I = I_0 e^{-t/\tau}$$

$$\tau = \frac{L}{R} \quad I_0 = \mathcal{E}/R$$

Orka í spólu  $U_L = \frac{1}{2} LI^2$

Orkuþéttleiki  $u_B = \frac{B^2}{2\mu_0}$

LC- sveiflur

$$\frac{d^2 Q}{dt^2} + \frac{1}{LC} Q = 0 \quad \omega_0 = \frac{1}{\sqrt{LC}}$$

Deyfðar LC-sveiflur

$$L \frac{d^2 Q}{dt^2} + R \frac{dQ}{dt} + \frac{Q}{C} = 0$$

$$Q = Q_0 e^{-Rt/2L} \cos(\omega' t + \delta)$$

$$\omega' = \sqrt{\omega_0^2 - \left(\frac{R}{2L}\right)^2}$$

Riðstraumur  $i = i_0 \sin(\omega t)$

$$v = v_0 \sin(\omega t + \phi)$$

rms gildi

$$I = \sqrt{(i^2)_{av}} = \frac{i_0}{\sqrt{2}} \approx 0.707 i_0$$

$$V = \sqrt{(v^2)_{av}} = \frac{v_0}{\sqrt{2}} \approx 0.707 v_0$$

$$X_L = \omega L \quad X_C = 1/\omega C$$

Samviðnám  $Z = \sqrt{R^2 + (X_L - X_C)^2}$

$$\tan \phi = \frac{X_L - X_C}{R}$$

Afl

$$P = I^2 R = IV \cos \phi$$

$$P = \frac{V^2 R}{R^2 + (\omega L - \frac{1}{\omega C})^2}$$

Spennir  $i_2 N_2 = i_1 N_1 \quad i_2 v_2 = i_1 v_1$

Maxwell

$$\oint \mathbf{E} \cdot d\mathbf{A} = \frac{Q}{\epsilon_0}$$

$$\oint \mathbf{B} \cdot d\mathbf{A} = 0$$

$$\oint \mathbf{E} \cdot d\ell = -\frac{d\Phi_B}{dt}$$

$$\oint \mathbf{B} \cdot d\ell = \mu_0 \left( I + \epsilon_0 \frac{d\Phi_E}{dt} \right)$$

Á diffurformi

$$\nabla \cdot \mathbf{E} = \frac{\rho}{\epsilon_0}$$

$$\nabla \cdot \mathbf{B} = 0$$

$$\nabla \times \mathbf{E} = -\frac{\partial \mathbf{B}}{\partial t}$$

$$\nabla \times \mathbf{B} = \mu_0 \left( \mathbf{J} + \epsilon_0 \frac{\partial \mathbf{E}}{\partial t} \right)$$

Öldulíkingar

$$\nabla^2 \mathbf{E} - \mu_0 \epsilon_0 \frac{\partial^2 \mathbf{E}}{\partial t^2} = 0$$

$$\nabla^2 \mathbf{B} - \mu_0 \epsilon_0 \frac{\partial^2 \mathbf{B}}{\partial t^2} = 0.$$

Um þætti sléttrar bylgju

$$\mathbf{E} = E_0 \sin(kz - \omega t) \hat{\mathbf{x}}$$

$$\mathbf{B} = \frac{1}{c} \hat{\mathbf{k}} \times \mathbf{E}$$

$$\mathbf{E} = -c \hat{\mathbf{k}} \times \mathbf{B}$$

$$c = (\mu_0 \epsilon_0)^{-1/2} \quad E = cB \quad c = \lambda f$$

Orkuþéttleiki

$$u = \epsilon_0 E^2 = \frac{B^2}{\mu_0} = \sqrt{\frac{\epsilon_0}{\mu_0}} EB$$

Poynting-vigur

$$\mathbf{S} = \frac{\mathbf{E} \times \mathbf{B}}{\mu_0} \quad S_{ave} = \frac{E_0 B_0}{2\mu_0}$$

Skriðþungi, geislaþrýstingur

$$p = \frac{U}{c} \quad \frac{F}{A} = \frac{S}{c} = u$$

### LJÓSFRAÐI

$$n = \frac{c}{v}$$

$$n_1 \sin \theta_1 = n_2 \sin \theta_2$$

$$\frac{1}{p} + \frac{1}{q} = \frac{1}{f}$$

$$m = \frac{y_1}{y_0} = -\frac{q}{p}$$

$$\frac{n_1}{p} + \frac{n_2}{q} = \frac{n_2 - n_1}{R}$$

$$\frac{1}{f} = (n - 1) \left( \frac{1}{R_1} - \frac{1}{R_2} \right)$$

$$\delta = m\lambda$$

$$m = 0, \pm 1, \pm 2, \dots$$

$$\delta = \left(m + \frac{1}{2}\right) \lambda$$

$$d \sin \theta = m\lambda$$

$$d \sin \theta = \left(m + \frac{1}{2}\right) \lambda$$

$$I = 4I_0 \cos^2\left(\frac{\phi}{2}\right)$$

$$a \sin \theta = m\lambda$$

$$d \sin \theta = m\lambda$$

$$I = I_0 \frac{\sin^2(\alpha/2)}{(\alpha/2)^2} \quad \alpha = 2\pi a \sin \theta / \lambda$$

Skautun

$$\text{Malus} \quad I = I_{max} \cos^2 \phi$$

$$\text{Brewster} \quad \tan \theta_p = \frac{n_b}{n_a}$$

### INNGANGUR AÐ SKAMMTAFRAÐI

Óvissulögmál Heisenberg

$$\Delta x \Delta p \geq \hbar$$

$$\Delta t \Delta E \geq \hbar/2$$

### ATÓM OG KJARNEDLISFRÆÐI

$$\lambda = \frac{h}{p} = \frac{h}{mv}$$

$$hf = \frac{hc}{\lambda} = E_f - E_i$$

Vetnislíkan Bohr

$$E_n = K_n + U_n = -\frac{1}{\epsilon_0^2} \frac{m e^4}{8n^2 h^2} = -\frac{hcR}{n^2}$$

$$L_n = m v_n r_n = n \frac{h}{2\pi}$$

Svarthlutageislunarlíkan Rayleigh

$$I(\lambda) = \frac{2\pi c k T}{\lambda^4}$$

Svarthlutageislunarlíkan Planck

$$I(\lambda) = \frac{2\pi h c^2}{\lambda^5 (\exp(hc/\lambda k T) - 1)}$$

$$1 \text{ u} = 1 \text{ amu} = 1 \text{ Da} = 1.660538921 \times 10^{-27} \text{ kg}$$

$$1 \text{ u} = 931.494095 \text{ MeV}/c^2$$

$$m_e = 0.511 \text{ MeV}/c^2$$

$$E_{rest} = m_0 c^2$$

$$E_{total} = mc^2$$

$$\alpha(t) = \lambda n(t)$$

$$T_{1/2} = \frac{\ln 2}{\lambda}$$

Massajafna Bethe og Weizsäcker

$$BE = a_v A - a_s A^{2/3} - a_c \frac{Z^2}{A^{1/3}} - a_a \frac{(N-Z)^2}{A} + \delta(A)$$

## STÆRÐFRÆÐI

$$\nabla \times (\nabla \times \mathbf{F}) = \nabla(\nabla \cdot \mathbf{F}) - \nabla^2 \mathbf{F}$$

Vigrar:

$$\mathbf{A} \cdot \mathbf{B} = AB \cos \theta = A_x B_x + A_y B_y + A_z B_z$$

$$\mathbf{A} \times \mathbf{B} = \begin{vmatrix} \hat{\mathbf{i}} & \hat{\mathbf{j}} & \hat{\mathbf{k}} \\ A_x & A_y & A_z \\ B_x & B_y & B_z \end{vmatrix}$$

$$|\mathbf{A} \times \mathbf{B}| = AB \sin \theta$$

$$\hat{\mathbf{C}} = \frac{\mathbf{C}}{|\mathbf{C}|}$$

Hornafræði:

$$C^2 = A^2 + B^2 - 2AB \cos \gamma$$

$$\frac{\sin \alpha}{A} = \frac{\sin \beta}{B} = \frac{\sin \gamma}{C}$$

$$\sin(x + y) = \sin x \cos y + \cos x \sin y$$

$$\cos(x + y) = \cos x \cos y - \sin x \sin y$$

$$\sin x + \sin y = 2 \sin\left(\frac{x+y}{2}\right) \cos\left(\frac{x-y}{2}\right)$$

$$\cos x + \cos y = 2 \cos\left(\frac{x+y}{2}\right) \cos\left(\frac{x-y}{2}\right)$$

$$\sin(-x) = -\sin x$$

$$\cos(-x) = \cos x$$

$$\sin 2x = 2 \sin x \cos x$$

$$\cos 2x = 2 \cos^2 x - 1$$

Raðir:

$$(1 + x)^n = 1 + nx + \frac{n(n-1)}{2}x^2 + o(x^3)$$

$$\ln(1 + x) = x - \frac{1}{2}x^2 + o(x^3)$$

$$\sin x = x + o(x^3)$$

$$\cos x = 1 - x^2/2 + o(x^4)$$

$$e^x = 1 + x + o(x^2)$$

Rúmheildi:

Kartísk hmit

$$\int dx \int dy \int dz f(x, y, z)$$

Sívalnings hmit

$$\int_0^R \rho d\rho \int_0^{2\pi} d\varphi \int_0^h dz f(\rho, \varphi, z)$$

Kúluhmit

$$\int_0^R r^2 dr \int_0^{2\pi} d\varphi \int_0^\pi \sin \theta d\theta f(r, \varphi, \theta)$$

Diffurvirkjar:

Kartísk hnit

$$\nabla V = \hat{\mathbf{x}} \frac{\partial V}{\partial x} + \hat{\mathbf{y}} \frac{\partial V}{\partial y} + \hat{\mathbf{z}} \frac{\partial V}{\partial z}$$

$$\nabla^2 V = \frac{\partial^2 V}{\partial x^2} + \frac{\partial^2 V}{\partial y^2} + \frac{\partial^2 V}{\partial z^2}$$

Sívalningshnit

$$\nabla V = \hat{\rho} \frac{\partial V}{\partial \rho} + \hat{\phi} \frac{1}{\rho} \frac{\partial V}{\partial \phi} + \hat{\mathbf{z}} \frac{\partial V}{\partial z}$$

$$\nabla^2 V = \frac{1}{\rho} \frac{\partial}{\partial \rho} \left( \rho \frac{\partial V}{\partial \rho} \right) + \frac{1}{\rho^2} \frac{\partial^2 V}{\partial \phi^2} + \frac{\partial^2 V}{\partial z^2}$$

Kúluhnit

$$\nabla V = \hat{\mathbf{r}} \frac{\partial V}{\partial r} + \hat{\theta} \frac{1}{r} \frac{\partial V}{\partial \theta} + \hat{\phi} \frac{1}{r \sin \theta} \frac{\partial V}{\partial \phi}$$

$$\begin{aligned} \nabla^2 V &= \frac{1}{r^2} \frac{\partial}{\partial r} \left( r^2 \frac{\partial V}{\partial r} \right) \\ &+ \frac{1}{r^2 \sin \theta} \frac{\partial}{\partial \theta} \left( \sin \theta \frac{\partial V}{\partial \theta} \right) \\ &+ \frac{1}{r^2 \sin^2 \theta} \frac{\partial^2 V}{\partial \phi^2} \end{aligned}$$